

S4Technology



S4TECHNOLOGY srl - via il Montale, 6 - 61020 Lunano (PU) - Italia - T. +39 0722 70 131 - F. +39 0722 721 985 - info@s4tech.it - www.s4tech.it

💡 INNOVATION ✎ DESIGN ⚙️ TECHNOLOGY

S4Technology



YOUR PARTNER FOR POLYURETHANE

Innovative technology and engineering
for parts in rigid structural polyurethane

Moulding, Painting and Assembling of plastic parts of rigid polyurethane with weight between 200 g. and 40 kg.

Stampaggio, verniciatura e assemblaggio di manufatti in plastica di poliuretano rigido con peso tra 200 g. e 40 kg.

S4TECHNOLOGY boasts a prominent position among the leading players in Italy, thanks to the latest equipment in terms of technology and productivity and decades of experience in polyurethane processing.

S4TECHNOLOGY is very flexible and able to manage all aspects of a project providing all the necessary services. Systems are in place to guarantee quality control and carefully managed logistics.

S4TECHNOLOGY vanta una posizione di spicco fra le principali aziende di settore in Italia, grazie all'utilizzo di impianti al top in termini di tecnologia e produttività e ad un'esperienza decennale nella lavorazione del poliuretano.

S4TECHNOLOGY è un'azienda molto flessibile in grado di gestire un progetto a 360° fornendo tutti i servizi necessari. Si avvale di sistemi di controllo e di qualità e di un'attenta gestione logistica.



 INNOVATION

 DESIGN

 TECHNOLOGY



S4TECHNOLOGY has developed a "lean production" to optimize the response time to the customer. A "just in time" characterized by the constant search for perfection.

S4TECHNOLOGY ha saputo ripensare i suoi processi in un'ottica di "produzione snella" per ottimizzare i tempi di risposta al cliente. Una produzione "just in time" caratterizzata dalla continua ricerca della perfezione.



S4TECHNOLOGY offers consultancy for the stages of concept and design, feasibility of the process and product. It works with designs from the client or from studios with the best technological solutions, planning the entire design process.

S4TECHNOLOGY offre una consulenza per le fasi di concept e design, di fattibilità prodotto e processo. Progetta con il cliente o con studi collegati le migliori soluzioni tecnologiche, pianificando l'intero iter progettuale.



Polyurethane RIM moulding technology with systems operated by the PLC, with the help of hydraulic presses and aluminum alloy moulds, guarantee a constant and reliable industrial production over time.

Lo stampaggio del poliuretano con tecnologia RIM gestito da sistemi PLC, con l'ausilio di presse idrauliche e stampi in lega di Alluminio, garantiscono una produzione industriale costante ed affidabile nel tempo.

INDUSTRIAL AREAS:

RENEWABLE AND SOLAR POWER
VENDING AND COFFEE MACHINES
MEDICAL / WELLNESS / COSMETIC
AUTOMOTIVE / SHIPBUILDING
WOODWORKING MACHINERY
GAMING / POS / VENDING MACHINE
FURNISHING / LIGHTING
INSTRUMENT PANELS
HOUSINGS FOR SPEAKERS

SETTORI INDUSTRIALI:

SOLARE ED ENERGIE RINNOVABILI
VENDING E MACCHINE DA CAFFÈ
MEDICALE / BENESSERE / ESTETICA
AUTOMOTIVE / NAVALE
MACCHINE LAVORAZIONI LEGNO
GAMING / POS / DISTRIBUTORI
ARREDAMENTO / ILLUMINAZIONE
QUADRI STRUMENTAZIONI
CASSE PER ALTOPARLANTI

YOUR PARTNER FOR POLYURETHANE

S4TECHNOLOGY has created an established network of partner businesses to guarantee completion activities such as finishing pieces, painting, printing and assembly.

S4TECHNOLOGY da anni ha saputo creare una rete di aziende partner selezionate, atte a garantire le attività di completamento: rifinitura del pezzo, verniciatura, serigrafie e montaggi.

CONSULTANCY

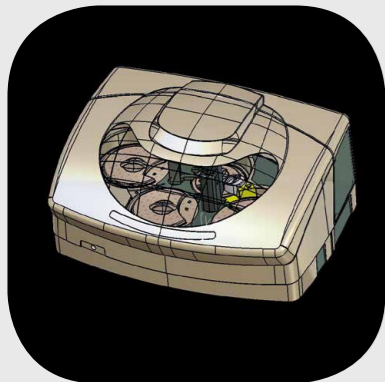

CO-DESIGN

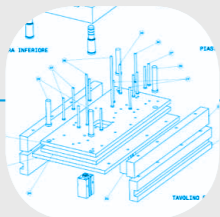
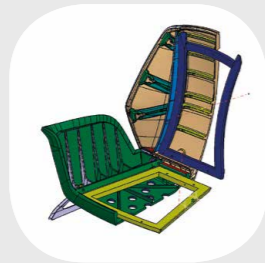

PLANNING

STRUCTURAL ANALYSIS

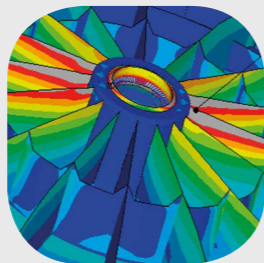

MANAGEMENT OF EQUIPMENT

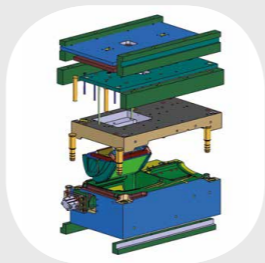

ENGINEERING

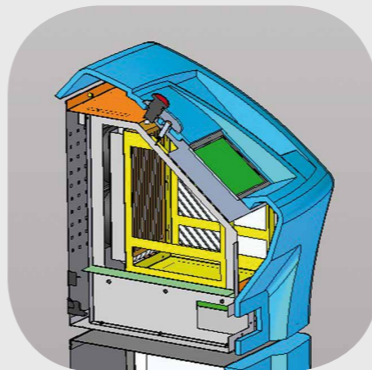

PROTOTYPES



ITEM MANUFACTURE

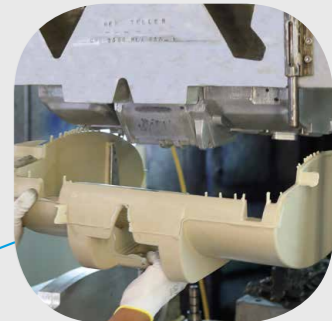

ITEM PAINTING



ITEM ASSEMBLY



YOUR PARTNER FOR POLYURETHANE

MOLDING of plastic parts of rigid polyurethane with weight between 200 g. and 40 kg.

CONSULTING, PLANNING, SCHEDULING, STRUCTURAL ANALYSIS, EQUIPMENT MANAGEMENT, PROTOTYPING, ENGINEERING, MANUFACTURED ITEMS.

PAINTING with opaque paints or lacquers of any RAL o Pantone colour, with any special paints or water-based paints.

ASSEMBLY of components and high-quality accessories, supplied by the customer or S4technology.

STAMPAGGIO manufatti di poliuretano rigido con peso tra 200 g. e 40 kg.

CONSULENZA, PROGETTAZIONE, PIANIFICAZIONE, ANALISI STRUTTURALI, GESTIONE ATTREZZATURE, PROTOTIPI, ENGINEERING, PRODUZIONE MANUFATTI.

VERNICIATURA con vernici coprenti o lacche con qualsiasi colore RAL o Pantone, con vernici speciali e con vernici ad acqua.

ASSEMBLAGGIO di componenti e accessori di elevata qualità, forniti dal cliente o da S4TECHNOLOGY.



S4Technology



S4TECHNOLOGY is also able to provide mass-coloured manufactured items, painted in the mould, and in mould coating, a technology with excellent advantages in terms of management and finished price.

S4TECHNOLOGY è inoltre in grado di fornire manufatti colorati in massa e verniciati in stampo, in mould coating, tecnologia con ottimi vantaggi di gestione e prezzo finale.

